



2018  
**SIERRA HD**

---



# UNRELENTING LIKE A PRO

The 2018 Sierra HD goes all in on premium. The trucks do it with quiet, refined interiors that put you in command of an available 6.6L Duramax Turbo Diesel engine—our most powerful ever—for robust hauling and trailering. They're the latest reminders that the same passion and purpose that drive you also drive us. We set our own standards and prove that Professional Grade isn't merely a label, it's a way of life. Sierra HD is the latest example of how we take a strong stance for what we believe in and pursue it like a pro.



SIERRA 2500HD SLT CREW CAB IN RED QUARTZ TINTCOAT (left)  
SIERRA 3500 DENALI HD CREW CAB WITH DUAL REAR WHEELS IN DARK SLATE METALLIC (center)  
SIERRA 2500 DENALI HD CREW CAB IN ONYX BLACK (right)  
Vehicles shown with available equipment.



## DESIGN

WHOEVER SAID YOU CAN'T JUDGE A BOOK BY ITS COVER NEVER LOOKED IN OUR DIRECTION. WITH STRENGTH AS A GUIDING PRINCIPLE, SIERRA HD IS DESIGNED TO BOLDLY REVEAL THE CAPABILITIES THAT LIE BENEATH.

# DENALI

## THE PEAK

Denali is the height of premium. With Sierra HD, Denali also becomes the pinnacle of engineering and design, producing nothing short of Professional Grade capability. Its purposeful design creates an impactful presence and helps reduce wind noise for a quiet, premium cabin. Not to be outdone, our most innovative cargo box also offers features to help you load and secure cargo. Choose Denali in either 2500HD or 3500HD and know you've reached the peak of GMC craftsmanship.

+ **New Denali Grille for 2018**

+ **6" Chromed Assist Steps**

+ **Power-Folding Vertical Trailing Mirrors**  
(Available 2500HD; Standard 3500HD)

+ **20" Chromed Aluminum Wheels** (2500HD Models)



SIERRA 2500 DENALI HD CREW CAB IN DARK SLATE METALLIC shown with available equipment.

## QUIETLY GOES ABOUT ITS BUSINESS

The Sierra Denali HD cabin combines triple door seals, inlaid doors, specialized powertrain mounts and other engineering achievements to create an exceptionally quiet environment. It's the solitude, comfort and craftsmanship you never expected in a heavy-duty pickup. Denali is also loaded with premium materials, along with French seam stitching, supportive heated and ventilated leather-appointed front bucket seats and generous storage. A hand-stitched heated leather-wrapped steering wheel and soft-touch instrument panel with burnished aluminum trim distinguish the premium-duty Sierra Denali HD from all others.

+ 12-Way Power Front Seats With Driver Memory

+ Standard Driver Alert Package

+ Denali-Exclusive Customizable Driver Display

+ Bose® Premium Seven-Speaker Audio System



SIERRA 2500 DENALI HD INTERIOR IN JET BLACK  
shown with available equipment.

# SLT

## BOLDLY GOES WHERE YOU WANT

The first thing you notice about the Sierra SLT is its bold, precisely sculpted design that looks smart and works efficiently. The large three-dimensional grille is designed to capture air to help cool the engine, while the remaining air flows smoothly around the truck. And since it's a Sierra HD, it produces robust payload and trailering capabilities.

- + GMC Signature Lighting With HID Projector-Beam Headlamps
- + Inlaid Doors Improve Aerodynamics to Reduce Wind Noise
- + Chrome-Accented Mirror Caps, Chrome Front Bumper Fascia, Bodyside Moldings and Door Handles
- + 20" Six-Spoke Polished Aluminum Wheels (Available on 2500HD Models)



SIERRA 3500HD CREW CAB SLT WITH DUAL REAR WHEELS IN DARK SLATE METALLIC shown with available equipment.

# ALL TERRAIN

## FOLLOW YOUR IMAGINATION, NOT A MAP

America's roads are great for taking us where we need to go. But to take us where we want to go, there's the Sierra HD All Terrain. It's available on 2500HD and 3500HD SLT Crew Cab single-rear-wheel models—all with 4WD. Sierra HD All Terrain is engineered to help you handle a variety of surfaces and conditions. So go where you want.

+ Off-Road Suspension With Twin-Tube Rancho® Shocks

+ Protective Underbody Shield

+ Selectable Electronic 4WD Transfer Case

+ High-Capacity Air Filter

+ Driver-Selectable Hill Descent Control

+ Off-Road Inclinometer in Driver Information Center

+ Available 20" Polished Aluminum Wheels With Dark Argent Accents (2500HD Models)

+ All-Terrain Tires

+ Black Tubular 4" Round Assist Steps

+ Spray-On Bedliner

+ Exclusive All Terrain Cabin Design

# ALL TERRAIN X

## DREAM BIGGER. A LOT BIGGER.

Trail-ready style. Signature refinement. The Sierra HD All Terrain X adds off-road style and attitude to an already bold truck. The All Terrain X Package is available on Sierra SLT 2500HD 4WD Crew Cabs.

**All Terrain X Tires** The LT275/65R18 Mud-Terrain-rated Goodyear® Wrangler DuraTrac® MT tires (shown at right) are designed for off-road competence in dirt, gravel and mud, with on-road composure in dry, wet or wintry conditions.

**Black Bed-Mounted Sport Bar** It's designed to support the available accessory Off-Road LED Lighting Package.

**Engines** A 6.0L V-8 with Direct Injection (DI) and Variable Valve Timing (VVT) is standard. A Duramax Turbo Diesel engine with 445 hp and 910 lb-ft of torque is available.

### PLUS:

- + Black B-Pillar Vinyl Wrap
- + Black, Heated, Power-Adjustable Trailering Mirrors With Memory, Power-Folding, Integrated Turn Signals and LED Rear Guidance Lamps
- + 18" Black Painted Aluminum Wheels



SIERRA 2500HD CREW CAB ALL TERRAIN X IN ONYX BLACK shown with available equipment.





## ENGINEERING

WHEN YOU'RE KNOWN FOR AMAZING FEATS OF ENGINEERING, YOU'RE CONSTANTLY LOOKING FOR A NEW GEAR TO SHIFT INTO. FORTUNATELY, WE FOUND IT WITHIN OURSELVES. YOU'LL FIND THE RESULT IN SIERRA HD.

## WORKS HARD. HARDLY BREAKS A SWEAT.

Sierra HD trucks are designed, engineered and built to help you achieve more with the heavy-duty capability of the available 6.6L Duramax Turbo Diesel paired with the Allison® 1000 transmission. Sierra Denali HD offers robust payload and trailering as well as premium comfort and technology.



SIERRA 3500 DENALI HD CREW CAB WITH DUAL REAR WHEELS IN ONYX BLACK shown with available equipment.



SIERRA 3500HD CREW CAB SLT IN RED QUARTZ TINTCOAT shown with available equipment.

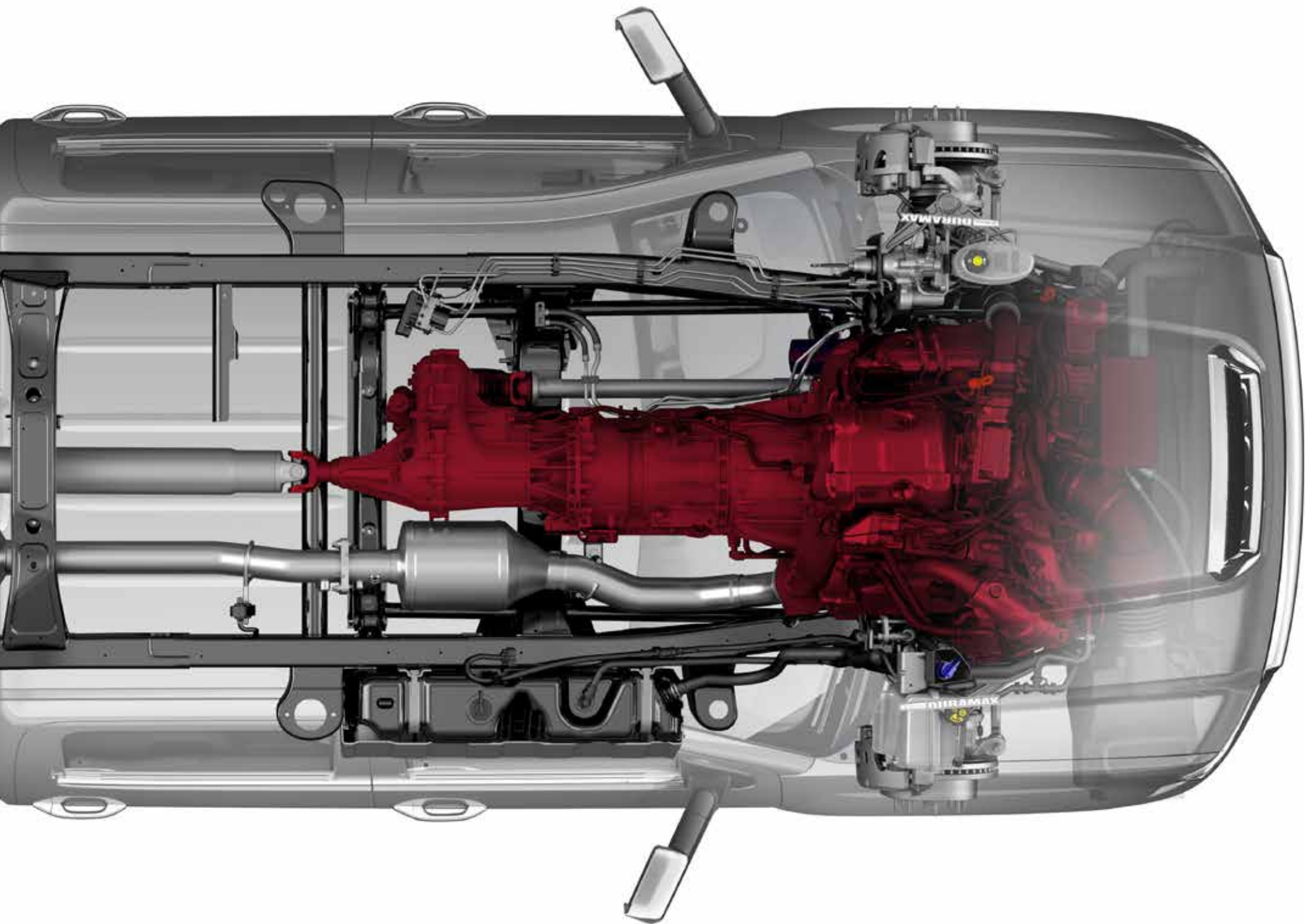

**445**  
**HORSEPOWER**  
**910**  
**lb-ft of**  
**TORQUE**  
**DURAMAX**

## OUR MOST POWERFUL DURAMAX DIESEL—EVER

Sierra HD gets its heavy-duty power from a proven source, the available Duramax 6.6L V-8 Turbo Diesel with 910 lb-ft of torque and 445 hp under your right foot. Prefer your power gasoline-fueled? Sierra HD comes standard with the force and efficiency of our 360-hp Vortec 6.0L V-8.

- + Hood-Scoop Induction System Provides Cooler Induction Air Temperatures to Maximize Horsepower (Duramax)
- + Large Radiator Capacity for Excellent Cooling Performance (Duramax)
- + Allison 1000 6-Speed Automatic Transmission (Duramax)

## THE TURNING POINT

GMC engineers love challenges. Sierra HD offers a steering system smart enough to tailor its response to your unique driving situation, in real time. Available Digital Steering Assist senses speed (especially important when trailering) to enable ease of handling at low speeds and improved steering feel at highway speeds. It also changes when the Tow/Haul button is activated, providing additional assist at reduced speeds and less at highway cruising speeds.

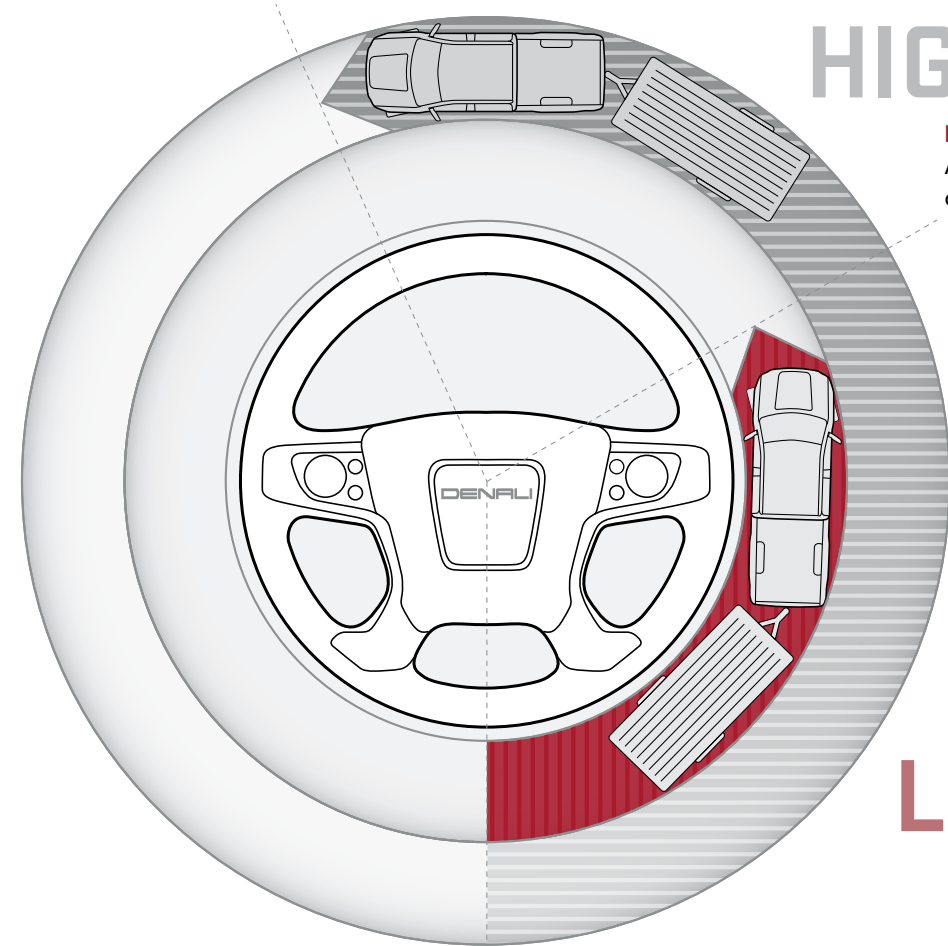

## HIGHWAY SPEED

**Highway Driving** While cruising at highway speeds, Digital Steering Assist decreases power assist to enhance road feel for heightened confidence and reduced driver fatigue on uneven roads.

## LOW SPEED

**Trailering & Parking** In low-speed situations, such as hitching up to a trailer or parking, Digital Steering Assist increases power steering assist for easier low-speed maneuverability.

## A STRUCTURE OF STRENGTH

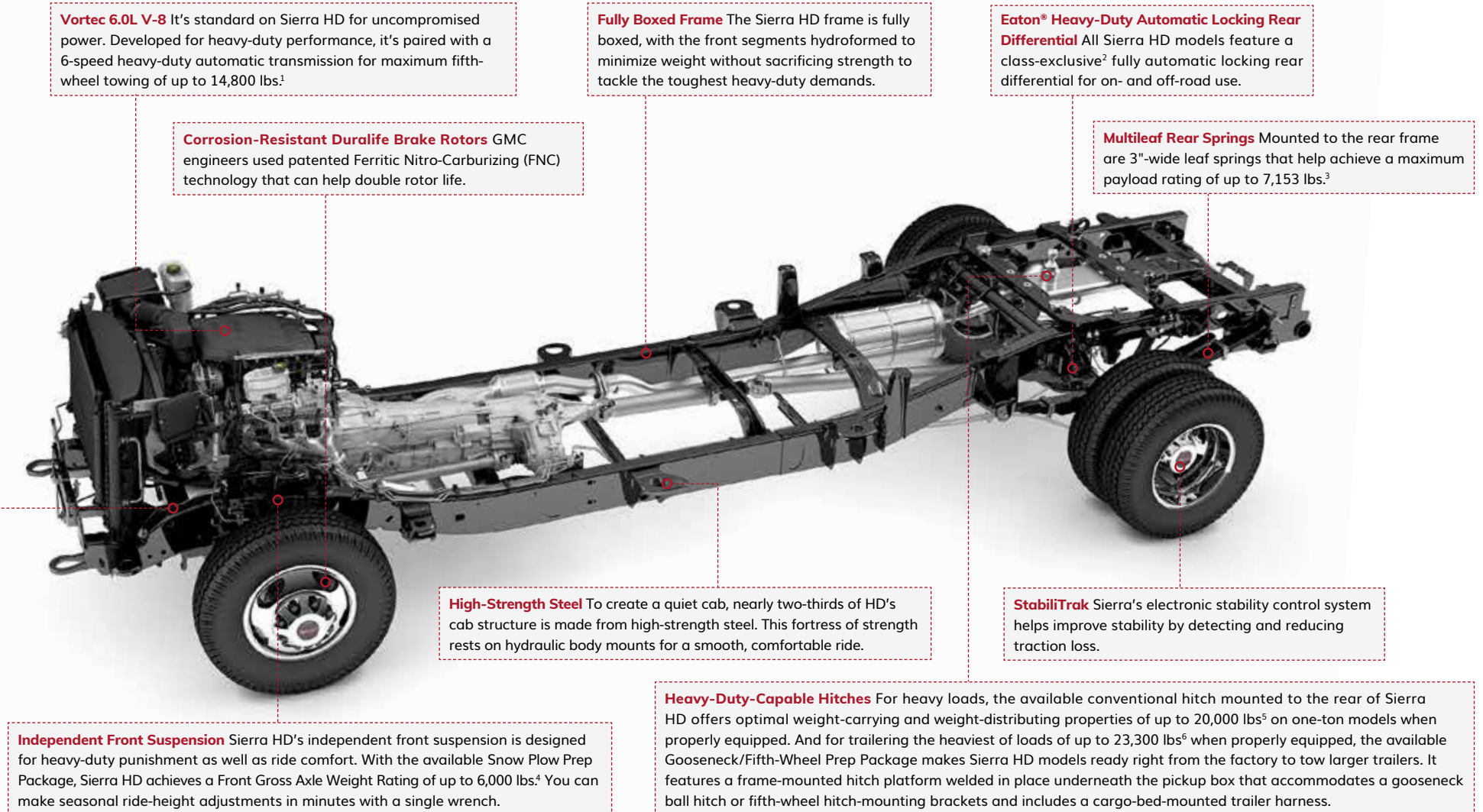

**Vortec 6.0L V-8** It's standard on Sierra HD for uncompromised power. Developed for heavy-duty performance, it's paired with a 6-speed heavy-duty automatic transmission for maximum fifth-wheel towing of up to 14,800 lbs.<sup>1</sup>

**Fully Boxed Frame** The Sierra HD frame is fully boxed, with the front segments hydroformed to minimize weight without sacrificing strength to tackle the toughest heavy-duty demands.

**Eaton® Heavy-Duty Automatic Locking Rear Differential** All Sierra HD models feature a class-exclusive<sup>2</sup> fully automatic locking rear differential for on- and off-road use.

**Corrosion-Resistant Duralife Brake Rotors** GMC engineers used patented Ferritic Nitro-Carburizing (FNC) technology that can help double rotor life.

**Multileaf Rear Springs** Mounted to the rear frame are 3"-wide leaf springs that help achieve a maximum payload rating of up to 7,153 lbs.<sup>3</sup>

**High-Strength Steel** To create a quiet cab, nearly two-thirds of HD's cab structure is made from high-strength steel. This fortress of strength rests on hydraulic body mounts for a smooth, comfortable ride.

**StabiliTrak** Sierra's electronic stability control system helps improve stability by detecting and reducing traction loss.

**Independent Front Suspension** Sierra HD's independent front suspension is designed for heavy-duty punishment as well as ride comfort. With the available Snow Plow Prep Package, Sierra HD achieves a Front Gross Axle Weight Rating of up to 6,000 lbs.<sup>4</sup> You can make seasonal ride-height adjustments in minutes with a single wrench.

**Heavy-Duty-Capable Hitches** For heavy loads, the available conventional hitch mounted to the rear of Sierra HD offers optimal weight-carrying and weight-distributing properties of up to 20,000 lbs<sup>5</sup> on one-ton models when properly equipped. And for trailering the heaviest of loads of up to 23,300 lbs<sup>6</sup> when properly equipped, the available Gooseneck/Fifth-Wheel Prep Package makes Sierra HD models ready right from the factory to tow larger trailers. It features a frame-mounted hitch platform welded in place underneath the pickup box that accommodates a gooseneck ball hitch or fifth-wheel hitch-mounting brackets and includes a cargo-bed-mounted trailer harness.

<sup>1</sup>Requires 2500HD Regular Cab 2WD with Vortec 6.0L V-8 gasoline engine and 4.10 rear axle ratio. Before you buy a vehicle or use it for trailering, carefully review the trailering section of the Owner's Manual. The weight of passengers, cargo and options or accessories may reduce the amount you can tow. <sup>2</sup>Excludes other GM vehicles. <sup>3</sup>Requires 3500HD Regular Cab DRW 2WD with 6.0L V-8 engine. These maximum payload ratings are intended for comparison purposes only. Before you buy a vehicle or use it to haul people or cargo, carefully review the vehicle loading section of the Owner's Manual and check the carrying capacity of your specific vehicle on the label on the inside of the driver's door jamb. <sup>4</sup>Capabilities and weight ratings are dependent upon model, engine, transmission and GVWR combinations. See your GMC dealer for details. <sup>5</sup>Requires 3500HD DRW model with available Duramax Diesel engine. Before you buy a vehicle or use it for trailering, carefully review the trailering section of the Owner's Manual. The weight of passengers, cargo and options or accessories may reduce the amount you can tow. <sup>6</sup>Requires 3500HD Regular Cab DRW 4WD model with available Duramax Diesel engine. Before you buy a vehicle or use it for trailering, carefully review the trailering section of the Owner's Manual. The weight of passengers, cargo and options or accessories may reduce the amount you can tow.

## OUR REPUTATION FOLLOWS US

We believe that it's not just how much you tow, it's how well you tow that matters. That's why Sierra HD's available Duramax Diesel combined with seamlessly integrated trailering technologies generate the confidence to control heavy loads, especially in challenging situations. Because we're not only building heavy-duty trailering machines, we're building confidence in those who drive them.

**Gooseneck/Fifth-Wheel Prep Package** Available on all cab and box types, this package includes a box-mounted seven-pin trailer harness and hitch platform to fit a gooseneck or fifth-wheel hitch for factory-installed durability.

**Premium Trailering Mirrors** The available heated, power-adjustable trailering mirrors include segment-first LED rear guidance lamps. The lamps are integrated into each mirror to enhance trailer visibility when backing up. Also included are amber auxiliary clearance lamps. When equipped on All Terrain, SLT and Denali models, the mirrors include driver memory and can also power-fold to help in car washes and other tight places.

**Diesel Exhaust Brake System** The available switch-activated Diesel Exhaust Brake System offers exhaust braking capability at low engine speeds. It's combined with the Allison 1000 transmission's Tow/Haul mode and Automatic Grade Braking features to reduce the amount of conventional braking needed while trailering or traveling downhill.

**Trailering Camera System** This available dealer-installed accessory system<sup>1</sup> produced by EchoMaster<sup>®</sup> provides several vantage points for confident trailering. Integrated into Sierra's center screen, the system offers multiple simultaneous views around Sierra. See your dealer for complete details.

**Trailer Brake Controller** For control and easy monitoring of your trailer brakes, Sierra HD offers an available integrated trailer brake controller. It's located high and in easy reach of the steering wheel for quick adjustments and is included on SLE, SLT, Denali and 3500HD models.

**Rear Vision Camera System** The center screen serves as your monitor for the Rear Vision Camera System. Its dynamic grid lines help when backing up or hitching a trailer.

**Trailer Sway Control** Helps keep both Sierra HD and your trailer heading in the same direction, automatically. Sensors help detect a swaying trailer, and the system helps bring it back in line by applying both the truck's and the trailer's brakes (when properly equipped).

**Tow/Haul Mode** To accelerate when trailering or hauling heavy loads, Tow/Haul mode raises transmission upshift points. It also raises downshift points using engine compression to help slow your Sierra HD instead of merely braking.

**Hill Start Assist** To give you extra time to switch from the brake pedal to the accelerator on a 5 percent grade or more, Hill Start Assist holds the brakes momentarily to help prevent rolling back.

**Transmission Temperature Gauge** Located in the Driver Information Center (DIC), it allows you to monitor the transmission fluid operating temperature in real time.



# 18,100 LBS

### 2500HD

Sierra 2500HD Regular Cab 2WD with the available Duramax Turbo Diesel and equipped with a gooseneck or fifth-wheel hitch allows you to trailer up to 18,100 lbs.<sup>2</sup>

# 20,000 LBS

### 3500HD Conventional Hitch

With the available Duramax Turbo Diesel engine, 3500HD dual-rear-wheel models offer a max conventional trailer weight rating of up to 20,000 lbs, when properly equipped.<sup>2</sup>

# 23,300 LBS

### 3500HD Gooseneck/Fifth-Wheel Hitch

The Sierra 3500HD Regular Cab 4WD dual-rear-wheel model with the available Duramax Turbo Diesel and equipped with a gooseneck or fifth-wheel hitch can pull even larger equipment, up to 23,300 lbs, when properly equipped.<sup>2</sup> The Double Cab can pull up to 23,200 lbs, when properly equipped.<sup>2</sup>

<sup>1</sup>The IntelliHaul Trailering Camera System is an Associated Accessory sourced from EchoMaster, an independent supplier, and is not warranted by GM or its dealers. GM is not responsible for the safety or quality of third-party supplier alterations. EchoMaster provides a 3-year/36,000-mile manufacturer's warranty. For details on the warranty provided by EchoMaster (Power Brand of AAMP Global), please call 1-866-766-2267. <sup>2</sup>Before you buy a vehicle or use it for trailering, carefully review the trailering section of the Owner's Manual. The weight of passengers, cargo and options or accessories may reduce the amount you can tow.



## FUNCTIONALITY

WE ALL NEED HOBBIES. BUT WHEN IT COMES TO GETTING THE GENUINELY HARD WORK ACCOMPLISHED, WHY GO AMATEUR WHEN ONLY PROFESSIONAL GRADE WILL DO?



SIERRA 2500 DENALI HD INTERIOR IN JET BLACK shown with available equipment.

## LOOKS LIKE A COCKPIT. PERFORMS LIKE A CONTROL TOWER.

Information gives us power. That's why Sierra HD positions information where it's easy to read at a glance (gauges are LED back-lit for enhanced night viewing) and controls are within reach. Sierra also offers advanced technologies to keep you connected, informed and in control of your surroundings.

**4G Wi-Fi® Hotspot<sup>1</sup>** Available 4G built-in Wi-Fi means a fast internet connection for up to seven web-enabled devices when Sierra is running. It's reliable, easy to use and can connect up to 50 feet around Sierra. Visit [onstar.com](http://onstar.com) for details.

**GMC Infotainment System<sup>2</sup>** The infotainment system features a 7" diagonal screen or available 8" diagonal screen for easy viewing and hands-free, voice-activated control of your smartphone. Stream music, sync MP3 music, receive vocalized text messages, benefit from Siri® Eyes Free<sup>3</sup> assistance, connect libraries from multiple devices and store phone contacts.

**Voice and Touch-Screen Navigation** In response to your voice or touch, Sierra HD's available Navigation System<sup>4</sup> displays 2-D or 3-D map graphics on the 8" diagonal center-mounted screen. Also included, NavTraffic<sup>5</sup> (with 3 trial months of SiriusXM) incorporates real-time traffic and road conditions, directing you toward the most efficient route.

**Rear Vision Camera System** The center screen also serves as your monitor for the rear-vision camera. Its dynamic grid lines help provide the perfect target when backing up or hitching a trailer.

**Customizable Driver Display** Denali's 8" diagonal color Driver Information Center (DIC) lets you choose from three selectable themes—Standard, Technology and Media—to select the information you see and how you see it. The display can be navigated with steering-wheel-mounted controls.

**Center Console Wireless Charging Mat<sup>6</sup>** Available wireless charging located on the center console lets you power up your compatible phone or device anytime the vehicle is running. No cords necessary.

<sup>1</sup>Requires a compatible mobile device, active service and data plan. 4G service available in select markets. Visit [onstar.com](http://onstar.com) for coverage map, details and system limitations. Data plan provided by AT&T.  
<sup>2</sup>Full functionality requires compatible Bluetooth® and smartphone. Some devices require USB connectivity. Data plan rates apply. <sup>3</sup>Requires GMC Infotainment System and compatible iPhone® running iOS 6 or newer. <sup>4</sup>Map coverage available in the United States, Puerto Rico and Canada. <sup>5</sup>If you decide to continue service after your trial, the subscription plan you choose will automatically renew thereafter and you will be charged according to your chosen payment method at then-current rates. Fees and taxes apply. To cancel, you must call SiriusXM at 1-866-635-2349. See SiriusXM Customer Agreement for complete terms at [siriusxm.com](http://siriusxm.com). All fees and programming subject to change. For more information about NavTraffic, visit [siriusxm.com/navtraffic](http://siriusxm.com/navtraffic). For more information about Travel Link, visit [siriusxm.com/travellink](http://siriusxm.com/travellink). Sirius, XM, SiriusXM and all related marks and logos are trademarks of SiriusXM Radio, Inc. <sup>6</sup>The system wirelessly charges one PMA- or Qi-compatible mobile device. Some devices require an adapter or back cover. To check for phone or other device compatibility, visit [my.gmc.com/learn](http://my.gmc.com/learn) for details.



SIERRA 3500 DENALI HD CREW CAB WITH DUAL REAR WHEELS IN RED QUARTZ TINTCOAT shown with available equipment.

## STOPS JUST SHORT OF LOADING ITSELF

Get to work. To help you do just that, Sierra HD offers our most innovative cargo box ever. The highlight of this collaboration between engineering and design is the widely acclaimed CornerStep rear bumper. But we didn't stop there.

**CornerStep Rear Bumper and Integrated Handgrips** Crafted into the corners, the bumper steps make it easy to access the cargo box. The depth of the step accommodates large boots, and ergonomically designed handgrips on the top of the side rails help give you a boost into the bed.

**Remote Power-Locking Tailgate** This available convenience allows you to lock or unlock the tailgate from the key fob.

**EZ-Lift and Lower Tailgate** Loading the cargo box takes less effort thanks to an available EZ-Lift and Lower Tailgate. It also keeps the tailgate from slamming down.

**Spray-On Bedliner** To provide a permanent, durable, nonskid surface, the available (standard on Denali, All Terrain and All Terrain X) black liner covers the entire bed below the side rails, including the tailgate, front box top rail and lower tie-down hooks. It's designed to protect Sierra's premium fit and finish.

**LED Under-Rail Lights** Available LED lights are conveniently positioned under each cargo box rail to make it easier to load or unload at night, or when the box is enclosed by a tonneau cover.

**Eight Tie-Down Hooks** In addition to four lower stationary hooks are four patented, load-bearing movable upper hooks. Rated at 250 pounds<sup>1</sup> each, the upper hooks can be repositioned in several places around the box depending on the cargo being secured.

**Bed Rail Protection** Simple yet all-too-important elements like standard rail protectors at the top of the box improve damage resistance. And to help reduce turbulence, a rear spoiler is integrated into the top of the tailgate.

**High-Strength Steel Bed** Unlike the stamped-steel process, a roll-formed process is used in Sierra HD's cargo bed floor to allow for a higher-grade steel that's stronger, lighter and more durable. Sierra HD offers a maximum payload capacity of more than 3 tons<sup>2</sup> (up to 7,153 pounds on 3500HD 2WD Regular Cab models with dual rear wheels and 6.0L V-8 engine).



CornerStep rear bumper and integrated handgrips



Tie-down hooks

<sup>1</sup>Cargo and load capacity limited by weight and distribution. <sup>2</sup>These maximum payload ratings are intended for comparison purposes only. Before you buy a vehicle or use it to haul people or cargo, carefully review the vehicle loading section of the Owner's Manual and check the carrying capacity of your specific vehicle on the label on the inside of the driver's door jamb.



## YOU CAN'T BE TOO AWARE

Sierra HD elevates pickup-truck safety by offering the Driver Alert Package. It includes Forward Collision Alert, Lane Departure Warning, Front and Rear Park Assist and the Safety Alert Seat.

**Rear Park Assist** This available feature alerts you to objects behind the truck.

**Rear Vision Camera System** The center screen serves as your monitor for the Rear Vision Camera System. Its dynamic grid lines help when backing up or hitching a trailer.

**Safety Alert Seat** This available seat warns you of potential traffic danger using directional vibration pulses from the seat cushion. Works with Forward Collision Alert, Lane Departure Warning and Front and Rear Park Assist.

**Lane Departure Warning** It's available to alert you when Sierra HD drifts over a lane line without signaling while traveling at least 35 mph.

**Front Park Assist** This available feature alerts you to objects in front of the truck.

**Forward Collision Alert** To help you prevent frontal crashes, this available technology alerts you when you are closing in on a vehicle ahead too quickly.

**Air Bags** Sierra HD offers up to six air bags<sup>1</sup> (standard on 2500HD and select 3500HD models), including frontal, head-curtain with rollover protection and front-seat-mounted side-impact air bags.

Safety features are no substitute for the driver's responsibility to operate the vehicle in a safe manner. The driver should remain attentive to traffic, surroundings and road conditions at all times. Read the vehicle Owner's Manual for important feature limitations and information.

<sup>1</sup>A NOTE ON CHILD SAFETY: Always use safety belts and the correct child restraint for your child's age and size, even with air bags. Even in vehicles equipped with the Passenger Sensing System, children are safer when properly secured in a rear seat in the appropriate infant, child or booster seat. Never place a rear-facing infant restraint in the front seat of any vehicle equipped with an active frontal air bag. See your vehicle Owner's Manual and child safety seat instructions for more safety information.

## BECAUSE NOT JUST ANY WHEELS WILL DO

Building a premium-duty truck like the Sierra HD means engineering every inch of it from the ground up—including the wheels it rides on. That's why you'll find a selection of GMC wheels in a range of styles and sizes for your Sierra HD. See your dealer for more availability details.

### 2500HD WHEELS



**17" Painted Steel (PYN)**  
Standard on 2500HD Sierra



**18" Painted Steel (PYT)**  
Available on 2500HD Sierra



**17" Machined Aluminum (PYQ)**  
Standard on 2500HD SLE;  
Available on 2500HD Sierra



**18" Chromed Aluminum (PYR)**  
Standard on 2500HD SLT; Included on  
2500HD All Terrain; Available on 2500HD SLE



**18" Black Painted Aluminum (RT4)**  
Included and only available with  
All Terrain X Package



**20" 5-Spoke Polished Aluminum (PYU)**  
Available on 2500HD SLE



**20" 6-Spoke Polished Aluminum (Q7R)**  
Available on 2500HD SLT



**20" 5-Spoke Polished Aluminum  
With Dark Argent Accents (RTH)**  
Available on 2500HD All Terrain

### DENALI HD SRW WHEELS



**20" Chromed Aluminum (RQA)**  
Standard on 2500 Denali HD



**18" Chromed Aluminum (PYR)**  
Standard on 3500 Denali HD SRW;  
Available on 2500 Denali HD



**18" Painted Steel (PYT)**  
Standard on 3500HD SRW Sierra



**18" Chromed Aluminum (PYR)**  
Standard on 3500HD SRW SLE and  
SLT; Included on 3500HD All Terrain

### 3500HD DRW WHEELS



**17" Painted Steel (PYW)**  
Standard on 3500HD DRW Sierra



**17" Painted Steel With Chrome  
Overlay (P06)**  
Standard on 3500HD DRW SLE and SLT



**17" Polished Forged Aluminum (RS7)**  
Standard on 3500 Denali HD DRW;  
Available on 3500HD Crew Cab DRW SLE and SLT

# ACCESSORIES

Go ahead, equip your Sierra HD exactly the way you want. Engineered to the same Professional Grade standards as your Sierra HD, GMC Accessories range from functional enhancements such as assist steps and storage systems to stylish accents.

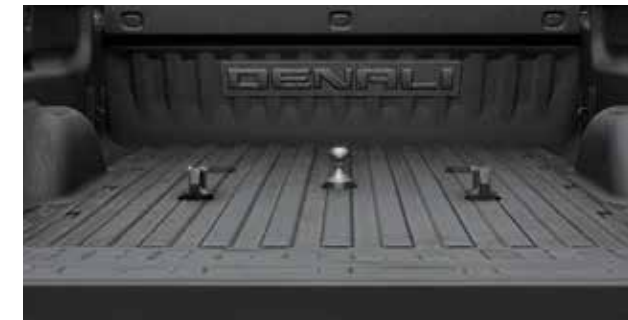

**Gooseneck Hitch Completion Package** Tow heavy loads confidently with your Sierra HD using this available gooseneck hitch completion package.<sup>1</sup>



**Trailing Camera System—Associated Accessories** This available dealer-installed accessory system,<sup>2</sup> produced by EchoMaster, provides several vantage points for confident trailering. The system offers multiple simultaneous views around Sierra HD, including views from left and right side-view mirror cameras and a trailer-mounted camera.



**Fifth-Wheel Hitch Package—Associated Accessories** Haul confidently with your Sierra HD using this available fifth-wheel hitch with standard legs by CURT.<sup>TM1,3</sup>



**Premium All-Weather Floor Liners** Sierra's available floor liners take all-weather floor mat coverage further with raised edges to help protect floor and trim contours.



**Stationary Toolbox** This available diamond-patterned toolbox features a cover with dual gas shocks for smooth opening and closing, and it features the GMC logo.



**Tonneau Covers** The available soft cover shields cargo and easily rolls up to allow full access to the bed. The available hard cover is tri-folding and adds strong content protection.

Associated Accessories listed are from an independent supplier and are not warranted by GM or its dealers. GM is not responsible for the safety or quality of third-party supplier alterations. For details on the warranty provided by Associated Accessories suppliers, please call the Associated Accessory supplier at the telephone number shown with the accessory listing. <sup>1</sup>Towing capacity is based on manufacturer specifications and assumes a properly equipped base vehicle. Consult your GMC dealer for details. Before you buy a vehicle or use it for trailering, carefully review the trailering section of the Owner's Manual. The weight of passengers, cargo and options or accessories may reduce the amount you can tow. <sup>2</sup>Non-GM warranty. EchoMaster provides a 3-year/36,000-mile manufacturer's limited warranty. For details on the warranty provided by EchoMaster [Power Brand of AAMP Global], please call 1-866-766-2267. <sup>3</sup>Non-GM warranty. CURT provides a 10-year limited manufacturer's warranty (limited lifetime warranty on select products). For details on the warranty provided by CURT Manufacturing, please call 1-877-287-8634.

**INSTRUMENT PANEL ACCENTS**



Axiom Aluminum    Dark Aluminum    Burnished Aluminum

**DOOR AND CONSOLE ACCENTS**

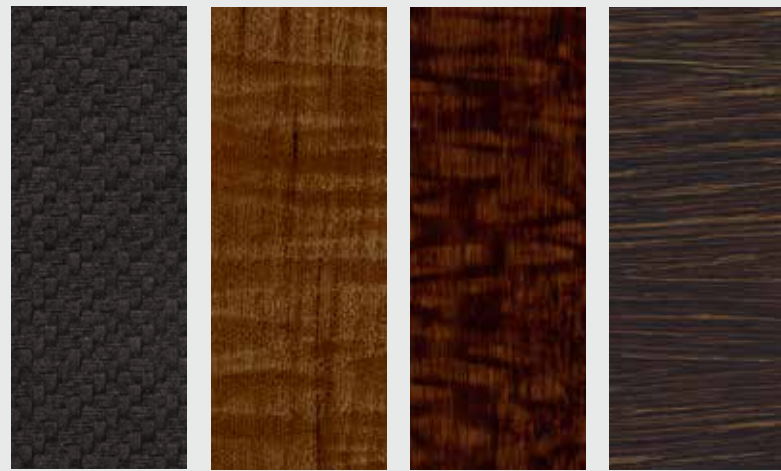

Off-Road Carbon Accent    Mineral Caster Wood Tone    Grand Lace Wood Tone    Oblique Hanon Oak Wood Tone

**INTERIOR COLORS/  
SEATING SURFACES  
VINYL    CLOTH**



Jet Black/Dark Ash Vinyl    Jet Black/Jet Black Cloth

**LEATHER APPOINTMENTS**



Jet Black/Dark Ash Cloth    Cocoa/Dune Cloth    Jet Black/Jet Black Leather-Appointed    Jet Black/Jet Black Perforated Leather-Appointed    Jet Black/Jet Black Leather-Appointed with Spice Red Accents    Jet Black/Dark Ash Leather-Appointed    Jet Black/Dark Ash Perforated Leather-Appointed    Cocoa/Dune Leather-Appointed    Cocoa/Dune Perforated Leather-Appointed    Cocoa/Dark Sand Perforated Leather-Appointed

**MODELS**

MODEL	Axiom Aluminum	Dark Aluminum	Burnished Aluminum	Off-Road Carbon Accent	Mineral Caster Wood Tone	Grand Lace Wood Tone	Oblique Hanon Oak Wood Tone	Jet Black/Dark Ash Vinyl	Jet Black/Jet Black Cloth	Jet Black/Dark Ash Cloth	Cocoa/Dune Cloth	Jet Black/Jet Black Leather-Appointed	Jet Black/Jet Black Perforated Leather-Appointed	Jet Black/Jet Black Leather-Appointed with Spice Red Accents	Jet Black/Dark Ash Leather-Appointed	Jet Black/Dark Ash Perforated Leather-Appointed	Cocoa/Dune Leather-Appointed	Cocoa/Dune Perforated Leather-Appointed	Cocoa/Dark Sand Perforated Leather-Appointed	
SIERRA	-	-	-	-	-	-	-	○	●	-	-	-	-	-	-	-	-	-	-	-
SLE	●	-	-	-	● <sup>1</sup>	● <sup>2</sup>	-	-	●	●	●	○	-	-	-	-	-	-	-	-
SLT	●	-	-	-	● <sup>1</sup>	● <sup>2</sup>	-	-	-	-	-	●	○	-	●	○	●	○	-	-
ALL TERRAIN	-	●	-	●	-	-	-	-	-	-	-	-	-	●	-	-	-	-	-	-
DENALI	-	-	●	-	-	-	●	-	-	-	-	-	● <sup>3</sup>	-	-	-	-	-	-	● <sup>3</sup>

KEY    ● STANDARD    ○ AVAILABLE    - NOT AVAILABLE

**EXTERIOR COLORS** [See your GMC dealer for more exterior color details and availability.]

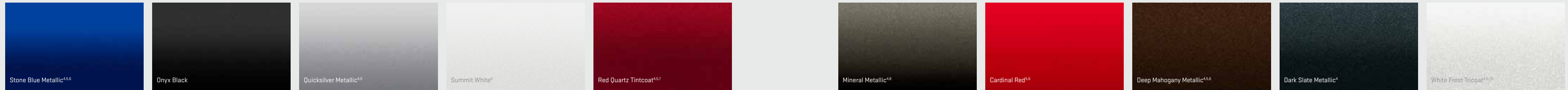

<sup>1</sup>With Cocoa/Dune interior color only.    <sup>2</sup>With Jet Black and Jet Black/Dark Ash interior color only.    <sup>3</sup>Includes unique Denali accents.    <sup>4</sup>Additional charge, premium paint.    <sup>5</sup>Not available with All Terrain Package or All Terrain X Package.    <sup>6</sup>Not available on Denali.    <sup>7</sup>Not available on base Sierra trim.    <sup>8</sup>Denali models only.    <sup>9</sup>Requires Crew Cab model.

## SIERRA HD SPECIFICATIONS

### CARGO DIMENSIONS<sup>1</sup>

DIMENSIONS	STANDARD BOX	LONG BOX SRW	LONG BOX DRW
Cargo Volume	61.0 cu. ft.	76.3 cu. ft.	76.3 cu. ft.
Inside Width at Floor (in.)	51.0	51.0	51.0
Box Length at Floor (in.)	78.9	97.8	97.8
Inside Box Height (in.)	21.2	21.2	21.3

EXTERIOR DIMENSIONS	REGULAR CAB	DOUBLE CAB	CREW CAB
Height (in.)	77.3-77.9 <sup>2</sup>	77.6-78.1 <sup>2</sup>	77.8-78.3 <sup>2</sup>
Overall Length (in.)			
Standard Box	—	230.0	239.5
Long Box	224.4	248.9	258.4

INTERIOR DIMENSIONS (in.)	REGULAR CAB	DOUBLE CAB	CREW CAB
Head Room (front/rear)	42.8/—	42.8/38.6	42.8/40.5
Leg Room (front/rear)	45.2/—	45.2/34.6	45.2/40.9
Shoulder Room (front/rear)	66.0/—	64.8/64.3	64.8/64.3
Hip Room (front/rear)	60.7/—	60.7/60.2	60.7/60.2

WHEELBASE (in.)	REGULAR CAB	DOUBLE CAB	CREW CAB
Standard Box	—	144.2	153.7
Long Box	133.6	158.1	167.7

### STANDARD TECHNICAL DATA

Series/Drive Type	2WD	4WD
BRAKES All models: Power 4-wheel antilock braking system	14" diameter 4-wheel disc (includes Duralife rotors)	14" diameter 4-wheel disc (includes Duralife rotors)
STEERING	Power recirculating ball with Smart Flow System	Power recirculating ball with Smart Flow System
FUEL TANK CAPACITY (Approx. gals.)	36.0	36.0
ALTERNATOR (amps)	150	150

MAXIMUM GVWR <sup>3</sup> (Gross Vehicle Weight Rating, lbs)	VORTEC 6.0L V-8/DURAMAX 6.6L V-8 TURBO DIESEL		
	REGULAR CAB	DOUBLE CAB	CREW CAB
2500HD			
Standard Box	—/—	9,500/10,000	9,500/10,000
Long Box	9,500/9,900	9,500/10,000	9,900/10,000
3500HD			
SRW	10,700/11,400	11,000/11,600	11,000/11,600
DRW	13,500/13,025	13,025/13,025	13,025/13,025

<sup>1</sup>Cargo and load capacity limited by weight and distribution. <sup>2</sup>Depending on model and tire size selected. <sup>3</sup>When properly equipped; includes weight of vehicle, passengers, cargo and equipment. <sup>4</sup>Capacities and weight ratings are dependent on model, engine, transmission and GVWR combinations. See your GMC dealer for details.

### ENGINES

	VORTEC 6.0L V-8 VVT (L96)	DURAMAX 6.6L V-8 TURBO DIESEL (L5P)
FUEL TYPE	Gasoline (FlexFuel)	Diesel (B20 biodiesel capable)
CAPACITY	6.0 liters (364 cu. in.)	6.6 liters (402 cu. in.)
SAE NET HORSEPOWER @ RPM	360 @ 5,400	445 @ 2,800
SAE NET TORQUE (LB-FT) @ RPM	380 @ 4,200	910 @ 1,600
ENGINE/ MODEL AVAILABILITY		
Regular Cab	●	○
Double Cab	●	○
Crew Cab	●	○

### SIERRA HD SUSPENSIONS

FRONT SUSPENSIONS <sup>4</sup> INDEPENDENT TORSION BAR—2500HD/3500HD			REAR SUSPENSIONS <sup>4</sup> SEMI-ELLIPTICAL MULTILEAF—2500HD/3500HD-SRW/3500HD-DRW		
STANDARD FRONT AXLE/ SPRING CAPACITY (lbs)	2WD	4WD	REAR AXLE/SPRING CAPACITY (lbs)	2WD	4WD
Regular Cab	4,400/4,400	4,400/4,400	Regular Cab	6,200/7,050/9,825	6,200/7,050/9,825
Double Cab	4,400/4,400	4,400/4,800	Double Cab	6,200/7,050/9,375	6,200/7,050/9,375
Crew Cab	4,400/4,400	4,800/4,800	Crew Cab	6,200/7,050/9,375	6,200/7,050/9,375

KEY ● STANDARD ○ AVAILABLE — NOT AVAILABLE









## EVEN OUR PROTECTION IS HEAVY-DUTY

Pro Grade Protection is standard on every 2018 Sierra HD. From maintenance to protecting your entire vehicle, you can drive with confidence.

+ Includes Two Maintenance Visits During the First 2 Years/24,000 Miles<sup>1</sup>

+ 3-Year/36,000-Mile Bumper-to-Bumper Limited Warranty<sup>2</sup>

+ 5-Year/60,000-Mile Powertrain Limited Warranty<sup>2</sup>

+ 5-Year/100,000-Mile Duramax Diesel Powertrain Limited Warranty<sup>2</sup>

+ 5-Year/60,000-Mile Roadside Assistance/Courtesy Transportation<sup>2</sup>

+ 5-Year/100,000-Mile Duramax Diesel Roadside Assistance/Courtesy Transportation<sup>2</sup>



## WE'RE AS CLOSE AS THE BLUE BUTTON

Connect to a specially trained Emergency Medical Dispatch-certified Advisor<sup>1</sup> just by pushing the blue OnStar button in your Sierra HD.

**Emergency: Help When It Matters Most.** OnStar protects you and your passengers in the event of an emergency with the right help, right when you need it.

**Automatic Crash Response.<sup>2</sup>** Using built-in sensors, Automatic Crash Response can connect you to an OnStar Advisor immediately after a crash to help get you the care you need even if you can't ask for it. Using Injury Severity Prediction technology, professionally trained Advisors can notify first responders about the likelihood of serious injury so they can provide the right help, right away. You can feel confident knowing you have a team, 24/7, to get you the assistance you need.

**Roadside Assistance.<sup>3</sup>** If you've got a flat tire or are low on gas, just push the blue OnStar button, and an Advisor will get things moving with Roadside Assistance. We can use GPS technology to pinpoint where you are and send a tow truck or whatever help you need. No matter how far you are from home, you're empowered with solutions that keep you moving.

**Crisis Assist.** During severe weather or a crisis, OnStar can provide critical guidance during your time of need. With Crisis Assist,<sup>2</sup> our Advisors provide a fast, knowledgeable resource for emergency assistance, special routing assistance and other services. We're a 24-hour connection and central point of contact for help when you need it most.

**Security: Protection You Can Count On.** Breathe easy knowing a comprehensive suite of Stolen Vehicle Assistance services is available to help protect your vehicle.

**Stolen Vehicle Assistance.<sup>4</sup>** If your vehicle is stolen, you can be assured OnStar Advisors are ready to take action. Once you report your vehicle stolen, they can pinpoint its location, work with the police to quickly recover it, slow the vehicle if the conditions are safe to do so and even prevent it from restarting. And with Theft Alarm Notification,<sup>5</sup> if your vehicle alarm sounds, we'll let you know via text, email and/or a phone call. One simple call puts a team into action to help recover your vehicle quickly and safely.

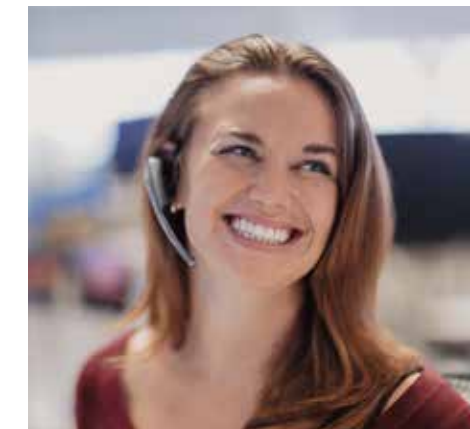

<sup>1</sup>Maintenance visits must occur within 2 years or 24,000 miles of vehicle delivery, whichever comes first. Does not include air filters. See participating dealer for other restrictions and complete details. <sup>2</sup>Whichever comes first. See dealer for limited-warranty details.

<sup>3</sup>Visit [onstar.com](http://onstar.com) for coverage map, details and system limitations. Some services require paid OnStar service plan. OnStar Advisors are certified by the International Academies of Emergency Dispatch. <sup>4</sup>Visit [onstar.com](http://onstar.com) for vehicle availability, details and system limitations. OnStar acts as a link to existing emergency service providers. Not all vehicles may transmit all crash data. <sup>5</sup>Roadside service provided by Allstate Roadside Services. <sup>6</sup>Services are subject to user terms and limitations, and vary by vehicle model. Requires subscription to Security Plan, Guidance Plan or Safety & Security Plan. These services are intended to assist with vehicle recovery, and do not prevent theft or protect against damage or loss. Visit [onstar.com](http://onstar.com) for more details. <sup>7</sup>Services are subject to user terms and other limitations and vary by vehicle model. Requires armed GM factory-installed theft-deterrent system; subscription to Security Plan, Guidance Plan or Safety & Security Plan; and selection of notification communication preference(s). Additional messaging and data rates may apply. Visit [onstar.com](http://onstar.com) for more details.

# CONVERSATION STARTER

At GMC, we'd like to start a dialogue with you so we can learn more about each other. Join the conversation and share your passion for all things Professional Grade.



GMC.COM



## IMPORTANT WORDS

### PRO GRADE PROTECTION

For 2018, Sierra HD comes with the Pro Grade Protection Plan, which includes two maintenance visits,<sup>1</sup> 3-year/36,000-mile Bumper-to-Bumper Limited Warranty<sup>2</sup> and 5-year/60,000-mile Powertrain Limited Warranty,<sup>2</sup> Roadside Assistance and Courtesy Transportation.

Starting with the owner orientation—and full tank of gas—you receive when you take possession of your Sierra HD, to the 24-Hour Roadside Assistance, Courtesy Transportation and Travel Benefits, you receive a portfolio of owner privileges that lasts throughout your warranty. For expert product information, Roadside Assistance or other services, call 1-800-GMC-8782.

**TRAVEL BENEFITS AND ROADSIDE ASSISTANCE** Available around the clock: trip routing service, a program for reimbursement for trip interruption due to necessary warranty repairs, towing, flat tire change, jump-starts and more for 5 years or 60,000 miles (whichever comes first).

**COURTESY TRANSPORTATION** Available at participating dealers: shuttle service, reimbursement of certain public transportation or fuel expenses for overnight warranty repairs and courtesy rental for overnight work repairs. See your dealer for details.

**GMC OWNER CENTER** A complimentary, one-stop resource to enhance your GMC ownership experience. It's easy to sign up. Just go to [gm.com/gmownercenter/gmc](http://gm.com/gmownercenter/gmc).

### ONSTAR AND GMC CONNECTED SERVICES

 Connected vehicle services require a paid connected vehicle services plan or trial, connected hardware, vehicle electrical system (including battery), wireless service and GPS satellite signal to be available and operating for features to function properly. OnStar acts as a link to existing emergency service providers. Visit [onstar.com](http://onstar.com) for coverage map, details and system limitations.

### SIRIUSXM SATELLITE RADIO

 SiriusXM Satellite Radio<sup>3</sup> is standard on select Sierra HD models. It includes 3 trial months of service. SiriusXM Satellite Radio makes your drive come alive with commercial-free music channels from virtually every genre, artist-dedicated channels, live performances and more. Tune in to live play-by-play from the biggest sports, exclusive entertainment from top personalities, compelling talk, hilarious comedy, world-class news, local traffic and weather and family-friendly programming. Welcome to the world of satellite radio. Visit [siriusxm.com](http://siriusxm.com) for details.

### GMC CERTIFIED SERVICE

 **GMC CERTIFIED SERVICE** To help your Sierra HD live up to its performance promise, GMC Certified Service—found exclusively at your GMC dealer—is there. With all the engineering excellence in Sierra HD, GM-trained technicians have the expertise to care for all of it.

### ADDITIONAL NOTES

**A NOTE ON CHILD SAFETY** Always use safety belts and the correct child restraint for your child's age and size, even with air bags. Even in vehicles equipped with the Passenger Sensing System, children are safer when properly secured in a rear seat in the appropriate infant, child or booster seat. Never place a rear-facing infant restraint in the front seat of any vehicle equipped with an active frontal air bag. See your vehicle Owner's Manual and child safety seat instructions for more safety information.

**TRAILERING AND OFF-ROAD INFORMATION** Please carefully review the Owner's Manual for important safety information about trailering or off-road driving in your vehicle.

**FLEET ORDERS** Some standard content may be deleted with fleet orders. See dealer for details.

**ENGINES** GMC products are equipped with engines produced by GM Powertrain or other suppliers to GM worldwide. The engines in GMC products may also be used in other GM makes and models.

**GMC.COM** See more of Sierra HD on our website: [gmc.com/sierrahd](http://gmc.com/sierrahd). More photos and information; hot links to related subjects; convenient dealer locator; pricing guide, spec out your own vehicle. Or call 1-800-GMC-8782.

## BUYPOWER CARD™



Now it's even easier to get into the GMC of your dreams. Every purchase gives you Earnings redeemable toward part or even all of a new GMC, Chevrolet, Buick or Cadillac. Every year, enjoy 5 percent Earnings on your first \$5,000 in purchases and 2 percent unlimited Earnings after that. No expiration on Earnings and no limit on how much you can earn or redeem. Learn more at [buypowercard.com/catalog](http://buypowercard.com/catalog). YOUR CARD IS THE KEY.™

**IMPORTANT WORDS ABOUT THIS CATALOG** We have tried to make this catalog comprehensive and factual. We reserve the right, however, to make changes at any time, without notice, in prices, colors, materials, equipment, specifications, models and availability. Specifications, dimensions, measurements, ratings and other numbers in this catalog and other printed materials provided at the dealership or affixed to vehicles are approximates based upon design and engineering drawings and prototypes and laboratory tests. Your vehicle may differ due to variations in manufacture and equipment. Since some information may have been updated since the time of printing, please check with your GMC dealer for complete details. GMC reserves the right to lengthen or shorten the model year for any product for any reason, or to start and end model years at different times. All competitive claims are based on the latest information available at the time of printing and GM Large Pickup segment.

**AN IMPORTANT NOTE ABOUT ALTERATIONS AND WARRANTIES** Installations or alterations to the original equipment vehicle (or chassis) as distributed by General Motors are not covered by the General Motors New-Vehicle Limited Warranty. The special body company, assembler, equipment installer or upfitter is solely responsible for warranties on the body or equipment and any alterations (or any effect of the alterations) to any of the parts, components, systems or assemblies installed by GM. General Motors is not responsible for the safety or quality of design features, materials or workmanship of any alterations by such suppliers.

**NEW-VEHICLE LIMITED WARRANTY** All GMC Sierra HD models come with a fully transferable, no-deductible 5-year/60,000-mile (whichever comes first) Powertrain Limited Warranty. GM vehicles registered in the USA are also covered for 3 years or 36,000 miles (whichever comes first). Coverage includes tires and towing to your nearest GMC dealership. Repairs will be made to correct any vehicle defect and most warranty repairs will be made at no charge. In addition, rust-through corrosion will be covered for 6 years or 100,000 miles (whichever comes first). Sierra HD also comes with two maintenance visits within the first 2 years/24,000 miles (whichever comes first).<sup>1</sup> See dealer for details.

**ASSEMBLY** GMC vehicles and their components are assembled or produced by different operating units of General Motors, its subsidiaries or suppliers to GM worldwide. We sometimes find it necessary to produce GMC vehicles with different or differently sourced components than originally scheduled. Since some options may be unavailable when your vehicle is assembled, we suggest that you verify that your vehicle includes the equipment you ordered or, if there are changes, that they are acceptable to you.

**GMMOBILITY.COM (1-800-323-9935)** GM Mobility offers financial assistance for eligible adaptive equipment to make automotive travel easier for persons with disabilities or special transportation needs. To learn more about special GM Mobility offers, visit [gmmobility.com](http://gmmobility.com).

<sup>1</sup>Maintenance visits must occur within 2 years or 24,000 miles of vehicle delivery, whichever comes first. Does not include air filters. See participating dealer for other restrictions and complete details. <sup>2</sup>Whichever comes first. See dealer for limited-warranty details. <sup>3</sup>If you decide to continue service after your trial, the subscription plan you choose will automatically renew thereafter and you will be charged according to your chosen payment method at then-current rates. Fees and taxes apply. To cancel, you must call SiriusXM at 1-866-635-2349. See SiriusXM Customer Agreement for complete terms at [siriusxm.com](http://siriusxm.com). All fees and programming subject to change. For more information about NavTraffic, visit [siriusxm.com/navtraffic](http://siriusxm.com/navtraffic). For more information about TravelLink, visit [siriusxm.com/travelink](http://siriusxm.com/travelink). Sirius, XM, SiriusXM and all related marks and logos are trademarks of SiriusXM Radio, Inc.

©2017 General Motors. All rights reserved. GM, the GM logo, GMC, the slogans, emblems, vehicle model names, vehicle body designs and other marks appearing in this catalog are the trademarks and/or service marks of General Motors, its subsidiaries, affiliates or licensors. Facebook is a registered trademark of Facebook, Inc. Twitter is a registered trademark of Twitter, Inc. YouTube is a registered trademark of Google Inc. Instagram is a registered trademark of Instagram, LLC. Android Auto is a trademark of Google Inc. Sirius, XM and all related marks and logos are trademarks of SiriusXM Radio, Inc. Apple and CarPlay are registered trademarks of Apple, Inc.

VISIT US AT GMC.COM